

1100 Handrail

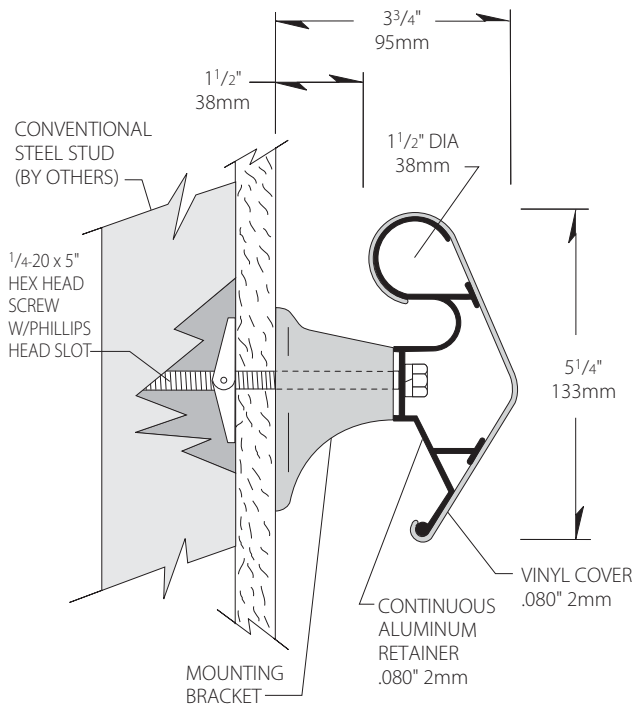

- 5 1/4" (133mm) height x 1 1/2" (38mm) gripping diameter, extends 3 3/4" (95mm) from wall
- Mounted on a sturdy .080" (2mm) thick, continuous aluminum retainer
- .080" (2mm) thick, scratch and stain resistant rigid vinyl cover
- Easy installation, clean-up and maintenance
- Approved in California by OSHPD for hospital use
- Meets ADA and ANSI criteria
- Manufactured in 12' (3.66m) standard lengths
- All mounting fasteners are included with each order
- Meets the most rigorous standards and criteria of chemical emissions as prescribed by the GREENGUARD Environmental Institute
- Has been tested and meets GREENGUARD Environmental Institute's and the state of California's requirements for low emitting products as tested by Air Quality Sciences
- Has been tested and meets the GREENGUARD Children & School chemical emissions levels



IPC.328/REV.5

1100 Handrail

Suggested Specifications

PART 1 - GENERAL

1.01 SUMMARY

A. Handrail systems for pedestrian safety and wall protection.

1.02 SECTION INCLUDES

A. 1100 Handrail System

1.03 REFERENCES

- A. American National Standards Institute (ANSI)
- B. American Society for Testing and Materials (ASTM)
- C. Americans with Disabilities Act (ADA)
- D. National Building Code of Canada (NBC)
- E. National Fire Protection Association (NFPA)
- F. Office of Statewide Health Planning and Development (OSHPD)
- G. Society of Automotive Engineers (SAE)
- H. Underwriters Laboratory (UL)
- I. Underwriters Laboratory of Canada (ULC)
- J. Uniform Building Code (UBC)

1.04 SYSTEM DESCRIPTION

- A. Performance Requirements: Provide handrail systems that conform to the following requirements of regulatory agencies and the quality control of IPC Door and Wall Protection Systems, InPro Corporation.
1. Fire Performance Characteristics: Provide UL Classified handrails conforming with NFPA Class A fire rating. Surface burning characteristics, as determined by UL-723 (ASTM E-84), shall be flame spread of 10 and smoke development of 350 - 450. Provide ULC (Canada) listed handrails conforming to the requirements of the National Building Code of Canada 2010, Subsection 3.1.13. Surface burning characteristics, as determined by CAN/ULC-S102.2, shall be flame spread of 15 and smoke developed of 35.
 2. Self Extinguishing: Provide handrails with a CC1 classification, as tested in accordance with the procedures specified in ASTM D-635-74, Standard Test Method for Rate of Burning and/or Extent and Time of Burning of Self-Supporting Plastics in a Horizontal Position, as referenced in UBC 52-4-1988.
 3. Impact Strength: Provide rigid vinyl profile materials that have an Impact Strength of 30.2 ft-lbs/inch of thickness as tested in accordance with the procedures specified in ASTM D-256-90b, Impact Resistance of Plastics.
 4. Chemical and Stain Resistance: Provide handrails that show resistance to stain when tested in accordance with applicable provisions of ASTM D-543.
 5. GREENGUARD Certified: Provide GREENGUARD Certified material. Profiles shall meet the requirements of GREENGUARD Certification Standards for Low-Emitting Products and GREENGUARD Product Emission Standard for Children & Schools.
 6. Fungal and Bacterial Resistance: Provide rigid vinyl that does not support fungal or bacterial growth as tested in accordance with ASTM G-21 and ASTM G-22.
 7. Color Consistency: Provide components matched in accordance with SAE J-1545 - (Delta E) with a color

difference no greater than 1.0 units using CIE Lab, CIE CMC, CIE LCh, Hunter Lab or similar color space scale systems.

8. Code Compliance: Provide handrails that comply with all current ANSI and ADA requirements. In California, IPC Handrails are approved by OSHPD for use in Hospitals. OSHPD approval #R-0232.

1.05 SUBMITTALS

- A. Product Data: Manufacturer's printed product data for each type of handrail specified.
- B. Detail Drawings: Mounting details with the appropriate fasteners for specific project substrates.
- C. Samples: Verification samples of handrail, 8" (203mm) long in full size profiles of each type and color indicated.
- D. Manufacturer's Installation Instruction: Printed installation instructions for each handrail.

1.06 DELIVERY, STORAGE AND HANDLING

- A. Deliver materials in unopened factory packaging to the jobsite
- B. Inspect materials at delivery to assure that specified products have been received.
- C. Store in original packaging in a climate controlled location away from direct sunlight.

1.07 PROJECT CONDITIONS

- A. Environmental Requirements: Products must be installed in an interior climate controlled environment.

1.08 WARRANTY

- A. Standard IPC Limited Lifetime Warranty against material and manufacturing defects.

PART 2 - PRODUCTS

2.01 MANUFACTURER

- A. Acceptable Manufacturer: IPC Door and Wall Protection Systems, InPro Corporation, PO Box 406, Muskego, WI USA; Telephone: 800.222.5556, Fax: 888.715.8407, www.inprocorp.com
- B. Substitutions: Not permitted
- C. Provide all handrails and wall protection from a single manufacturer.

2.02 MANUFACTURED UNITS

- A. Handrail Profile
 1. 1100 Handrail, 5¹/₄" (133mm) height x 1¹/₂" (38mm) gripping diameter, extends 3³/₄" (95mm) from wall. Options: Curved handrail, specify radius. Minimum radius - 4 feet (1.22m)

2.03 MATERIALS

- A. Vinyl: Snap-on covers of .080" (2mm) thickness shall be extruded from chemical and stain resistant polyvinyl chloride with the addition of impact modifiers. No plasticizers shall be added (plasticizers may aid in bacterial growth).
- B. Aluminum: Continuous aluminum retainer of .080" (2mm) thickness shall be fabricated from 6063-T5 aluminum, with a mill finish.

2.04 COMPONENTS

- A. Returns, outside corners and brackets shall be made of injection molded thermoplastics.
- B. Fasteners: All mounting system accessories appropriate for substrates indicated on the drawings shall be provided.

2.05 FINISHES

- A. Vinyl Covers: Handrail color to be selected by the architect from the IPC finish selection. Surface shall have a pebblette texture.
- B. Molded components: Outside corners, returns and brackets shall be of a color and pattern matching the handrails. Surface shall have a pebblette texture.

PART 3 - EXECUTION

3.01 EXAMINATION

- A. Examine areas and conditions in which the handrail systems will be installed.
 1. Complete all finishing operations, including painting, before beginning installation of handrail system materials.
 - B. Wall surface shall be dry and free from dirt, grease and loose paint.

3.02 PREPARATION

- A. General: Prior to installation, clean substrate to remove dust, debris and loose particles.

3.03 INSTALLATION

- A. General: Locate handrail as indicated on the approved detail drawing for the appropriate substrate and in compliance with the IPC installation instructions. Install handrail level and plumb at the height indicated on the drawings.
- B. Installation of 1100 Handrail:

1. Cut the aluminum retainer to the desired length, allowing 4¹/₈" (105mm) for each return, 1¹/₄" (6mm) for each outside corner.
2. Attach returns, outside corners and brackets to the aluminum retainer. It is recommended that brackets are installed 4" (102mm) from the ends of a run. Spacing of brackets is recommended to be a maximum of 32" (813mm).
3. Mount the aluminum retainer to the wall using the provided fasteners. Level and secure the aluminum retainer to the wall.
4. Cut the vinyl cover to fit between the returns and/or outside corners. NOTE: Trim all factory edges square before installation. Position the vinyl cover on the aluminum retainer starting at the top of the retainer and pivoting the vinyl cover over the bottom of the retainer until it snaps into place.

3.04 CLEANING

- A. At completion of the installation, clean surfaces in accordance with the IPC clean-up and maintenance instructions.

